



KDR-PS/2 series

Dual rail 15"/17"/19" LCD console with PS/2 KVM switch

KDR-PS/2 series provide industrial level input solution to optimize your space utilization by controlling your system in just 1U rack space. With KDR-PS/2 series, you can control 8 / 16 platforms by using built-in PS/2 KVM switch and easily expand the connections up to 8 levels with the combination of KVM switch boxes.



Features

- Dual rails for independent panel and keyboard tray
- Hidden handle for keyboard tray
- Support Sun native resolution
- Support 17 various keyboard languages
- Bright Active Matrix TFT display
- OSD function (On Screen Display) for LCD display
- Durable keyboards (touchpad or trackball)
- Panel protected by tempered glass
- DC power (optional)

Application

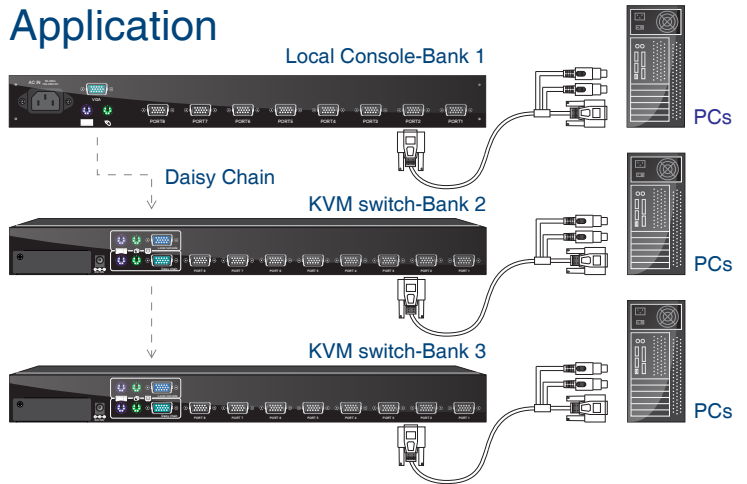

Specification

Model Name	KDR-11508 / KDR-11516	KDR-11708 / KDR-11716	KDR-11908 / KDR-11916
System Connections	8 / 16	8 / 16	8 / 16
Dimension	569.8 x 443.4 x 44 mm / 22.4 x 17.5 x 1.7 inches	569.8 x 443.4 x 44 mm / 22.4 x 17.5 x 1.7 inches	631.3 x 443.5 x 44 mm / 24.9 x 17.5 x 1.7 inches
Package Dimension	728 x 553 x 205 mm / 28.7 x 21.8 x 8.1 inches	728 x 553 x 205 mm / 28.7 x 21.8 x 8.1 inches	788 x 564 x 185 mm / 31.0 x 22.2 x 7.3 inches
Net Weight	11.5 Kg / 25.4 lbs	13.0 Kg / 28.7 lbs	14.0 Kg / 30.9 lbs
Gross Weight	17.5 Kg / 38.6 lbs	19.5 Kg / 43.0 lbs	21.5 Kg / 47.4 lbs
Display Size	15 inches	17 inches	19 inches
Panel Type	Active Matrix TFT LCD	Active Matrix TFT LCD	Active Matrix TFT LCD
Resolution Capabilities	Max. up to 1024 x 768 (XGA)	Max. up to 1280 x 1024 (SXGA)	Max. up to 1280 x 1024 (SXGA)
Pixel Pitch	Supports 0.297 mm x 0.297 mm	Supports 0.264 mm x 0.264 mm	Supports 0.098 mm x 0.294 mm
Viewing Angle (CR>10)	Right-Left view 130° (Typ) Up-Down View 100° (Typ)	Right-Left view 176° (Typ) Up-Down View 170° (Typ)	Right-Left view 140° (Typ) Up-Down View 140° (Typ)
Contrast Ratio	400 : 1	450 : 1	500 : 1
Brightness	White 250 cd/m ² (Center 1 point Typ)	White 300 cd/m ² (Center 1 point Typ)	White 300 cd/m ² (Center 1 point Typ)
Back Light	Dual Lamps for Back Light	Four Lamps for Back Light	Four Lamps for Back Light
Supported Colors	16M Colors (6-bit with FRC)	16.7M Colors (8-bit with FRC)	16.7M Colors (8-bit with FRC)
Response Time	Rising Time 5 ms, Decay Time 11 ms	Rising Time 2 ms, Decay Time 14 ms	Rising Time 2 ms, Decay Time 10 ms
Power Consumption	16 W, 10.41 W for Panel	25W, 19.05W for Panel	25 W, 21.05 W for Panel
Operating System	Dos, Windows (3.1, 9x, 2000, NT4, ME, XP, 2003 Server) Linux, Novell 3.12-6, HP UX, SUN		
Signal Cable	KC - 1501C		
Keyboard Mouse	106 key PS/2 keyboard with touch pad		
Sync	45 ~ 80 KHz		
Power Source	100 ~ 240 VAC input		
Temperature	Operate 0 ~ 50 °C / 32 ~ 122 °F Storage -20 ~ 60 °C / -4 ~ 140 °F		
Humidity	10% ~ 90% RH		
Chassis Construction	Heavy duty steel materials		
Keyboard Language	US, UK, German, French, Spanish, Italian, Portuguese, Dutch, Swiss, Belgium, Swedish, Norwegian, Danish, Japanese, Mandarin, Russian, Hebrew		

Specification

PS/2 KVM Switch		
Connector (All Female Types)	PC Port Connectors	8 / 16 x HDDB 15-pin
	Daisy Chain Connectors	1 x VGA HDDB 15-pin 2 x PS/2 Mini Din 6-pin
	Power Connector	1 x AC Inlet
Max. Distance (KVM switch -- Host)	5 m (16 feet)	
Daisy Chain Port	Support Daisy Chain function with 8-layer Bus topologies	
PC selection	On Screen Display (OSD) Menu, Hot Key	
Security	Provide ACL (Access Control List) security function, store up to 8 independent controllable PC lists	

Options

- Color (Black / Beige / OEM color)
- Cherry keyboard with trackball(PS/2 only)
- DC power (- 48V ~ + 48V with additional cost / + - 12V without additional cost)
- Rear bracket extension up to 1030mm
- Detachable keyboard plate
- Signal cable 1.8m / 3.0m / 5.0m

Dimension

